

Plunger Lock - Smart Lock

Enhance customer service and increase sales



Plunger II and III Locks are designed to secure cabinets with metal frame doors, wood bypass doors and glass sliding doors. Our Plunger Locks are easily retrofittable for pre-drilled holes in exist-ing furniture. The operational efficiency, improved customer service and speed to check out makes Smart Lock the perfect locked cabinet solution.

- › Sales associates are empowered to access locked display cabinets, delivering a more timely response to customers
- › Enhanced interaction with customers will result in increased sales
- › Part of the IR Ecosystem, a one key solution to storewide security.

FEATURES AND BENEFITS (PLUNGER LOCK II)

- › Designed for glass sliding and wood doors.
- › Simple to retrofit and install – lock mounts quickly to metal arm of sliding panel doors (22mm (0.87”) hole required).
- › Includes wood and metal screws and mounting bracket.
- › Lock Status Indicator provides visual confirmation that lock is locked or unlocked.



Lock Status Indicator



FEATURES AND BENEFITS (PLUNGER LOCK III)

- › Designed for glass sliding doors.
- › Simple to retrofit and install – fits easily to glass bypass doors (designed to fit 22mm to 32mm (0.87”-1.26”) hole).
- › Screws, mounting bracket and optional spacer rings included.
- › Spacer rings allow mounting in holes ranging from 22mm to 32mm (0.87”-1.26”.)
- › Lock Status Indicator provides visual confirmation that lock is locked or unlocked.



Lock Status Indicator



SPECIFICATIONS

PL202:

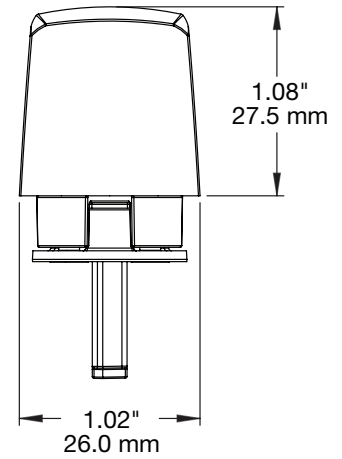
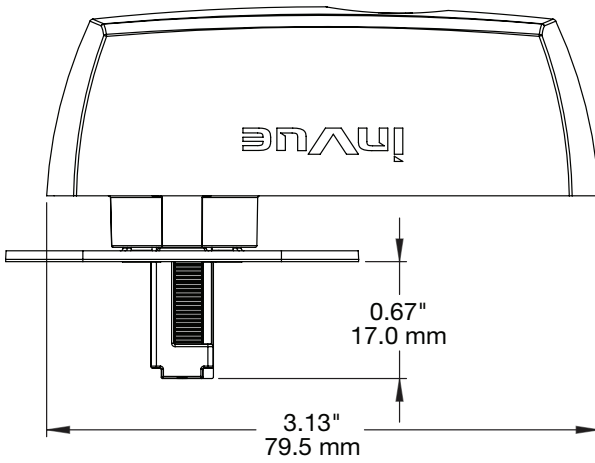

SPECIFICATIONS

PL203:

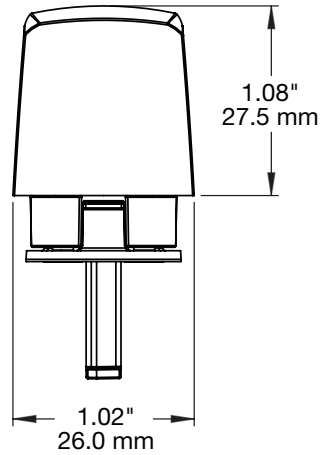
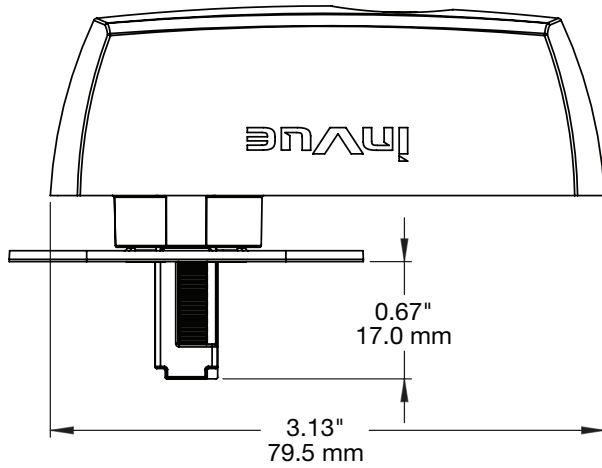

A storewide single key solution to increase profits.

OneKEY[™]
ecosystem

The Plunger Lock is part of the exclusive InVue OneKEY ecosystem[™], a storewide single key solution that improves customer service, increases sales and provides high theft protection.

©2020 InVue. No endorsement of InVue products has been made by any of the manufacturers of the products shown. Product is sold pursuant to InVue's warranty which can be found at invue.com/warranty.